

# Listwa T100Z – montaż wariant 1

1.

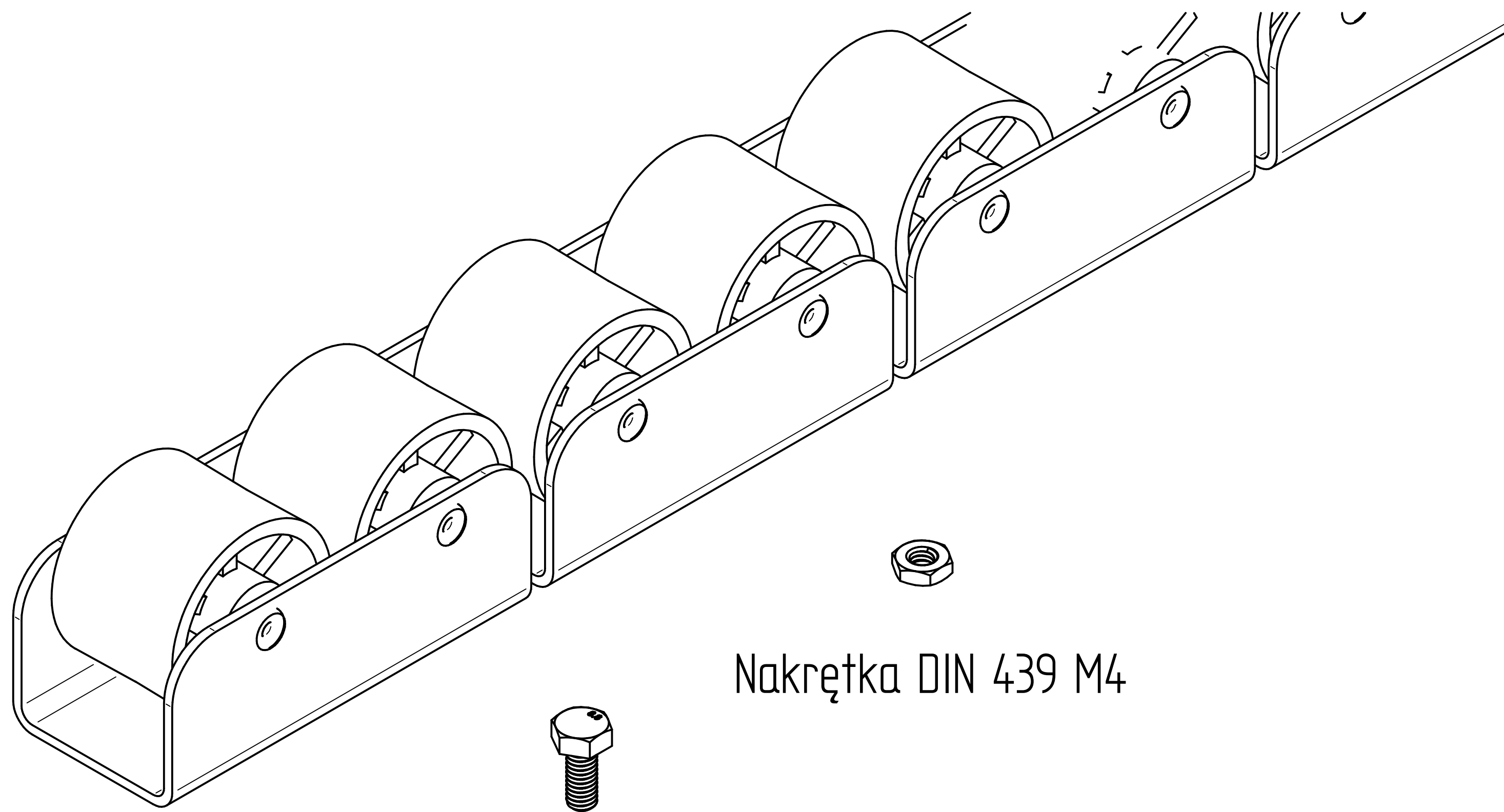

Nakrętka DIN 439 M4

Listwa T100Z

Śruba DIN 933 M4

2.

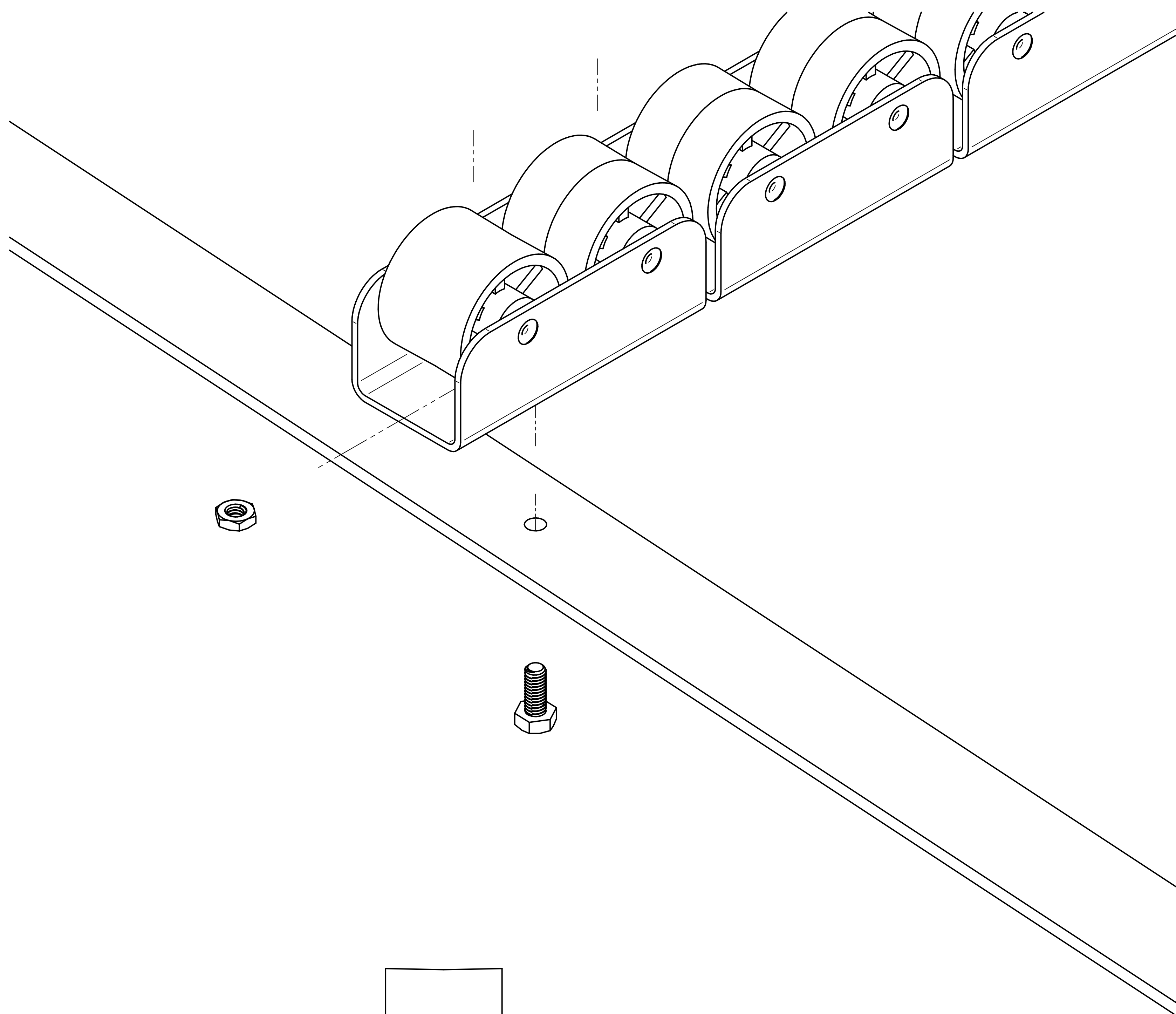

3.

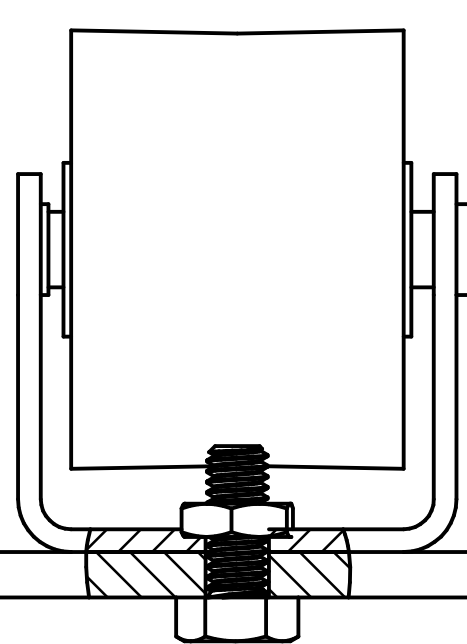

# Listwa T100Z – montaż wariant 2

1.

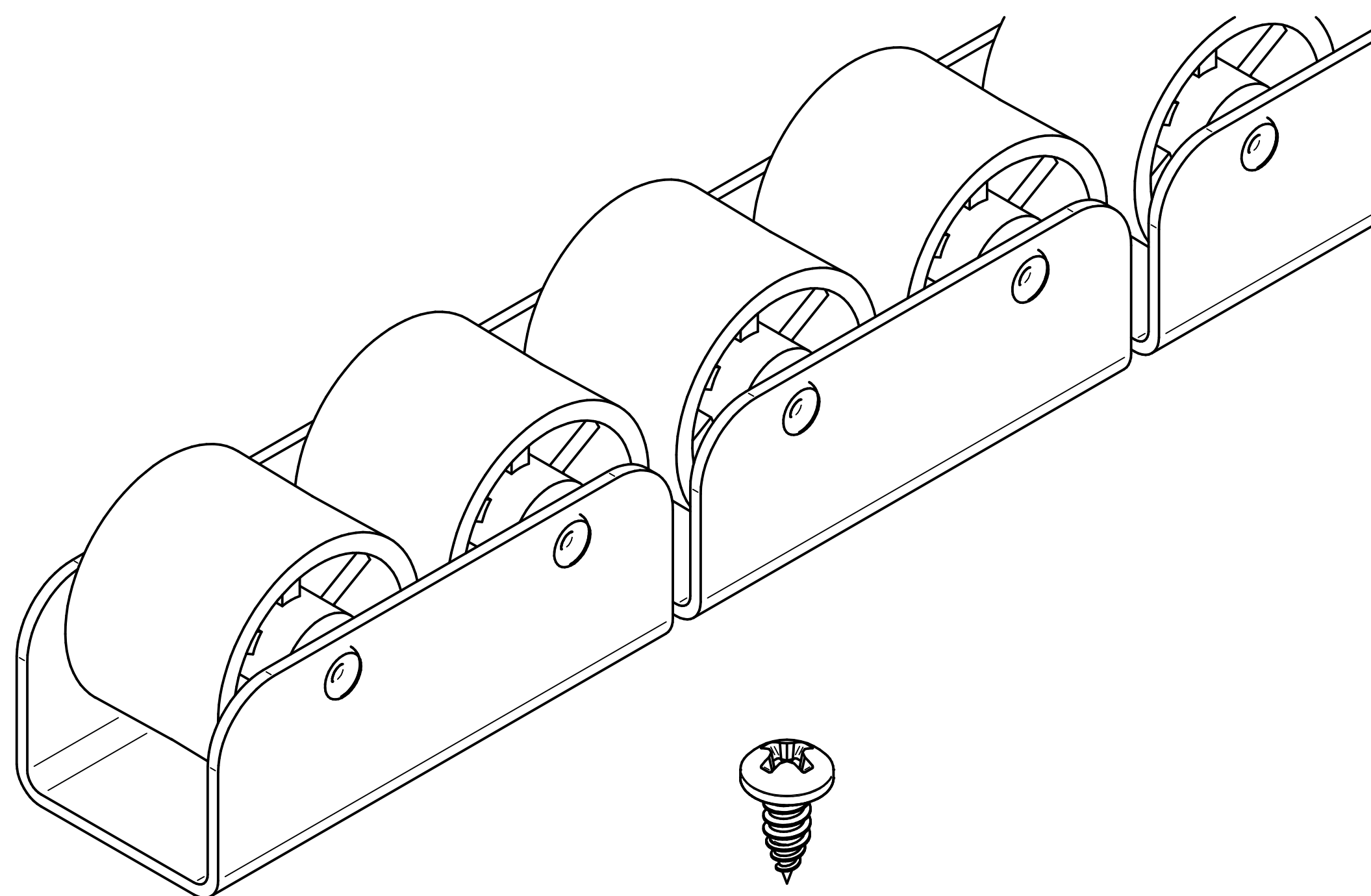

Listwa T100

Blachowkręt ST4,8

2.

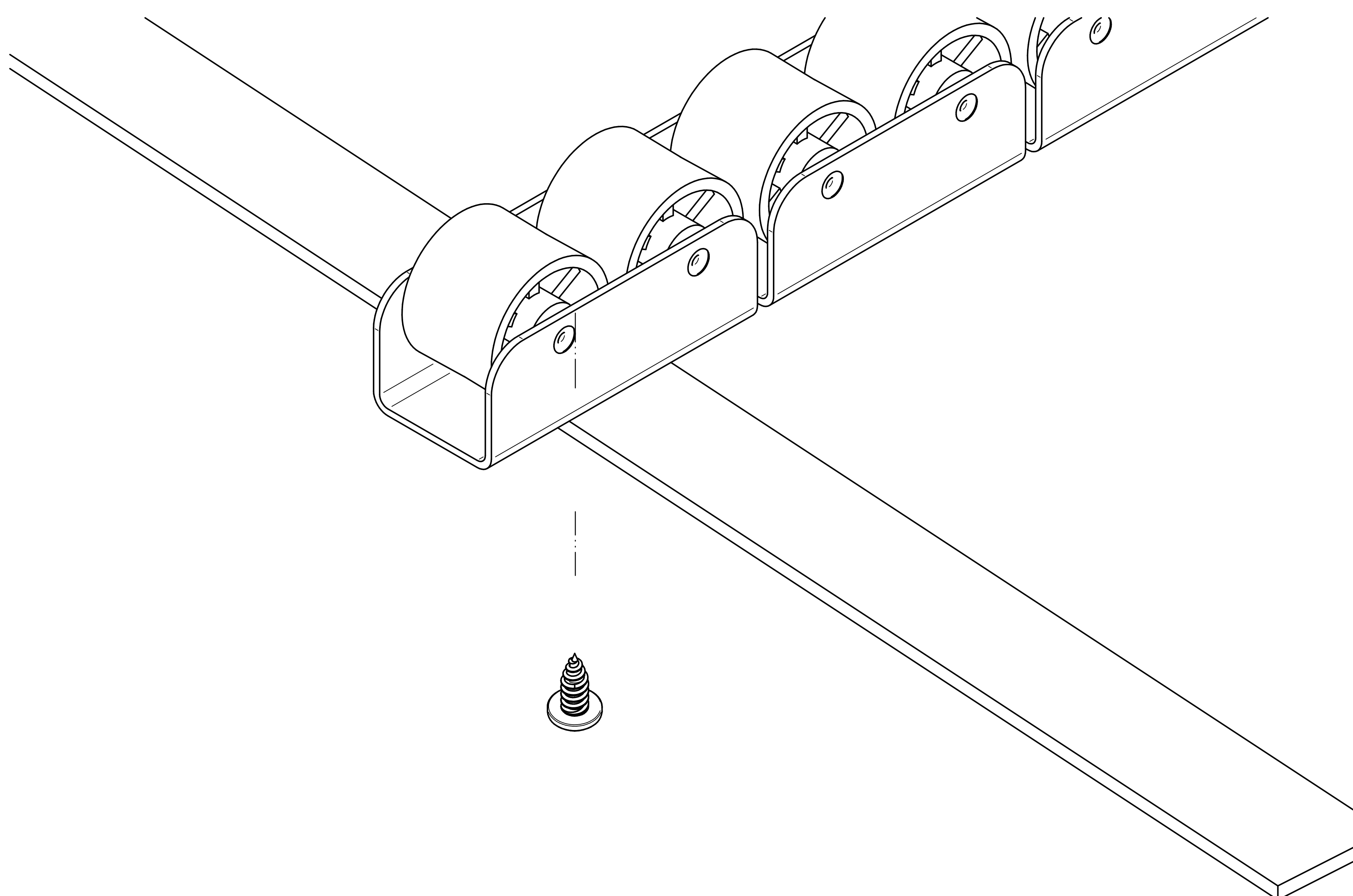

3.

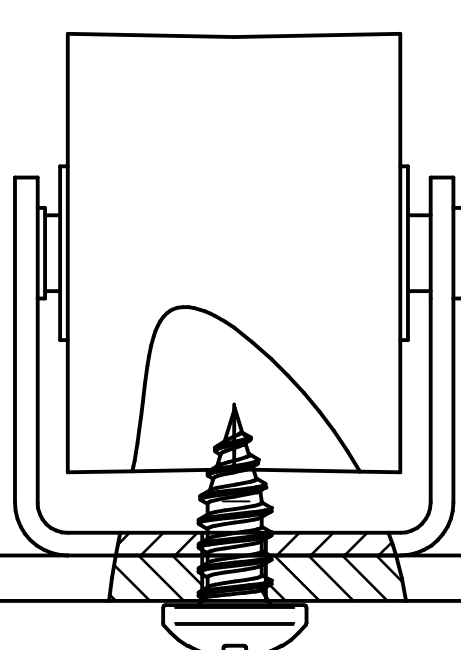

# Listwa T100Z – montaż wariant 3

1.

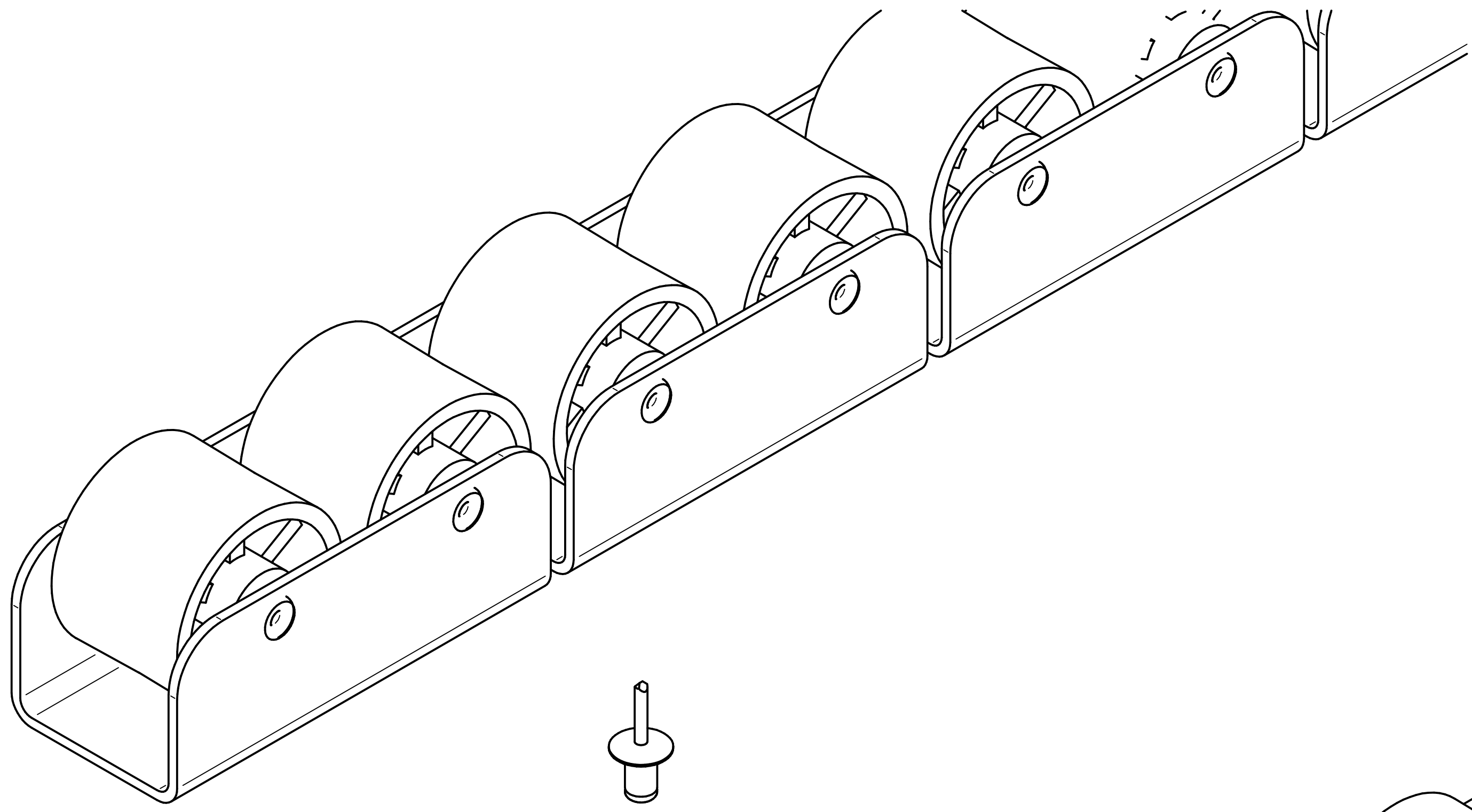

Listwa T100Z

Nit zrywalny fi4

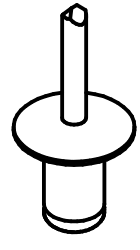

2.

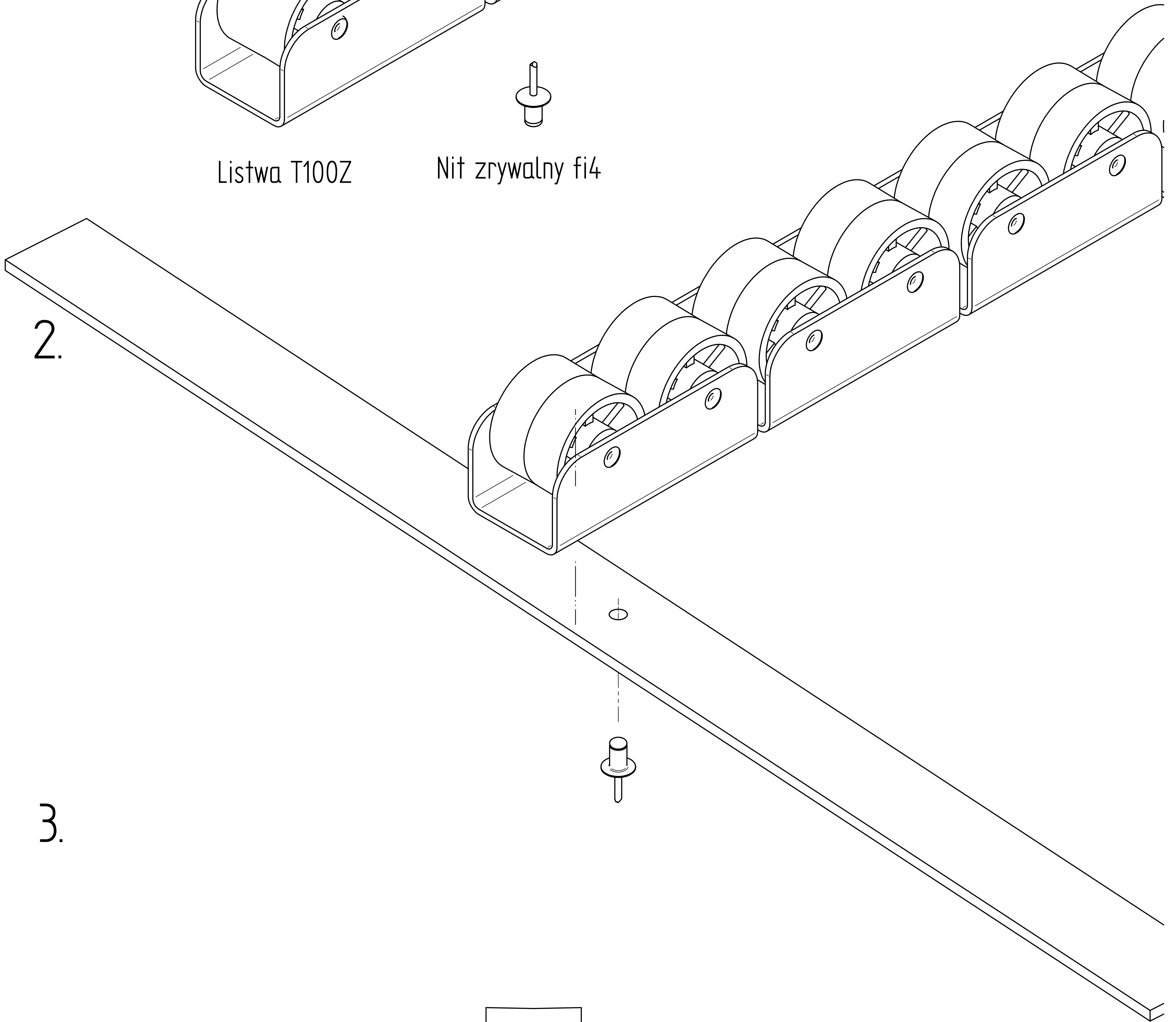

3.

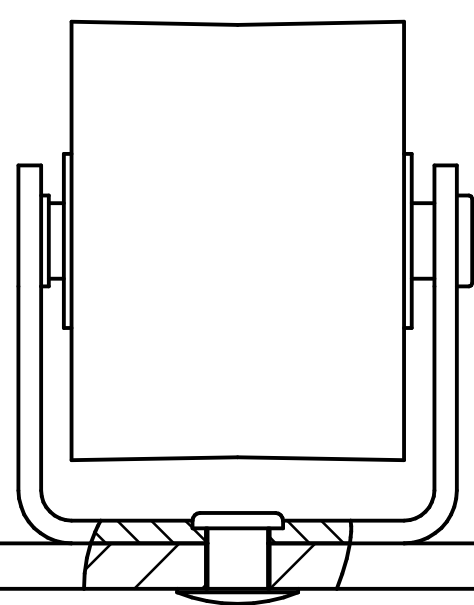

# Listwa T100Z – montaż wariant 4

1.

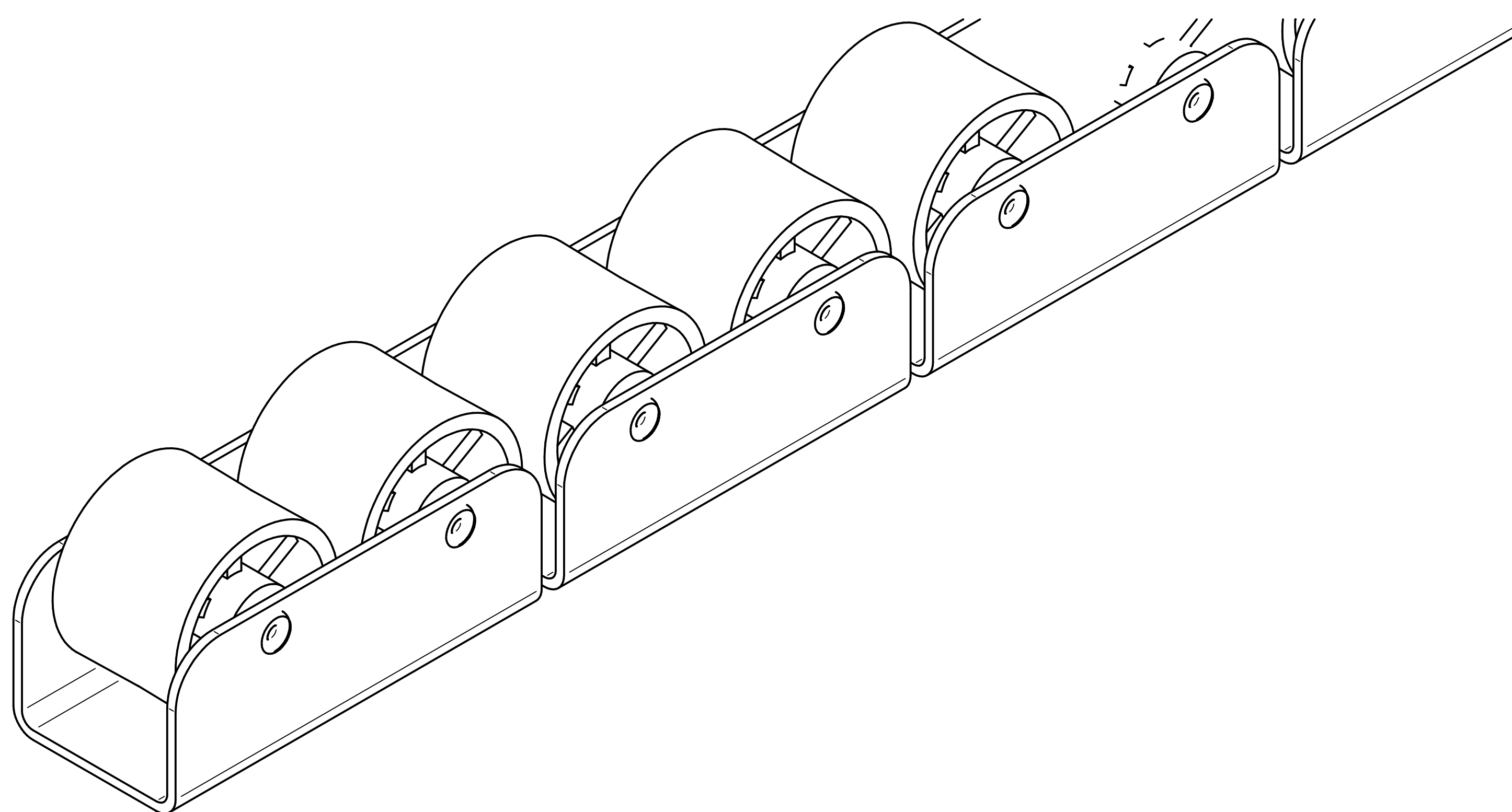

Listwa T100Z

2.

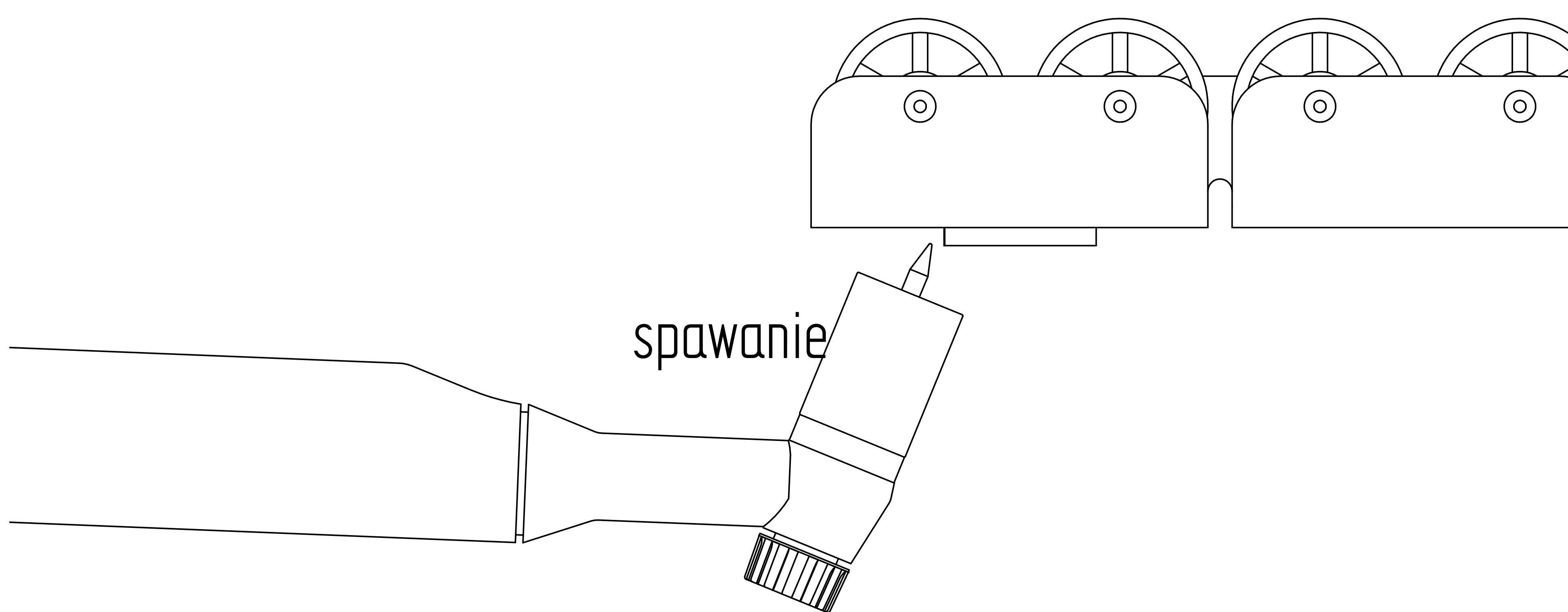

Rolki należy schłodzić bezpośrednio po spawaniu